



DESIGN AND DEVELOPMENT OF A LOW-COST 3D METAL PRINTER

¹Dr M Lavanya, ²K Sunitha, ³K Archana

¹²³Department of Mechanical Engineering, St.martin's Engineering College, India-500 100

ABSTRACT

3D printing or additive manufacturing (AM) is a technology that enables the fabrication of 3D data by depositing a thin layer of material layer-by-layer until a final product is produced. Recently, the application of metal-based material has been increasingly utilized. However, the price is expensive and limited to certain applications only. Thus, it severely restricts access to the technology for small and medium enterprises. Realizing its potential, this research focuses on the design and development of a low – cost 3D metal printer. The basic construction, process, and operation to develop a low-cost 3D metal printer are presented along with the material costs, connection of electronic part, and illustration of metal inert gas (MIG) welding. In order to test the newly developed low-cost 3D metal printer's performance, the main parameters that influence the accuracy and quality of a metal product are tested. The 3D printed structure's accuracies are examined and compared to computer-aided design data (CAD) data. The cross-sectional area of the samples was captured using SEM to check for the bonding between inter layer. Based on the study, it was found that a relatively acceptable 3D printed metal structure can be produced from the newly developed low-cost 3D metal printer. Thus, while having explored the potential of using the developed solution, it also opens-up into the area of further investigation particularly in the precision of observed over desired.

KEYWORDS

Additive manufacturing, 3-D printing, wire arc additive manufacturing, open source 3D printing.

1. INTRODUCTION

3D printing or additive manufacturing (AM) is a group of technologies that are used to build prototypes, physical models and finished parts from three-dimensional (3D) computer aided design (CAD) data [1]. Study showed the technology has developed rapidly and has proven its effectiveness, especially for design and small production [2-4]. According to research, AM technology allowed for the direct fabrication of physically complex shapes from its corresponding CAD with minimum adjustments by using a layer-by-layer deposition technique [5-7]. This is one of the attractive characteristics of objects generated by 3D printing. In fact, the increasing application of 3D printing technology has driven manufacturers and individuals to improve the machine, especially for process fabrication. Compared to the traditional process which requires jigs, moulds, and tools during the manufacturing of a product, the use of 3D printing eliminates some of these requirements. A scholar said this technology has revolutionized the production process and slowly replacing conventional manufacturing process [8]. Thus, the use of 3D printers assists the production process and therefore saves a great deal of time and money.

The rapid growth of 3D printers has the potential to change the manufacturing industry in the coming years. Recently the presence of open source system allows the 3D printer to be built with low cost of fabrication. According to previous research, this extremely increase the popularity and growth of low cost 3D printer since open source system allowed anyone to redistribute, study and modify without restriction [9,10]. The open source models that are already available is such as RepRap, fab@home, and Ultimaker. The RepRap open source or replicating rapid prototyping is the most famous and successful open source project [11]. It was started by Adrian Boyer from the University of Bath (UK) in 2005. The aim was to establish a 3D printer capability which can repeat a significant number of its own structural components [12]. In years 2008 to 2010, the estimated number of RepRap users had increased from 4 to 4500 [13].

Recently, there has been an increase in demand of metal prototypes and tools. The introduction of non-polymeric material, including metal has been widely used in 3D printing applications. Based on a study, direct metal prototypes can be approached using processes such as selective laser sintering (SLS), direct metal deposition (DMD), shape metal deposition (SMD), electron beam melting, and the most recent plasma deposition manufacturing process [14-19]. The different welding techniques may influence the mechanical properties of the metal parts produced, and the selection process depends on the required deposition velocity, size and surface quality. Based on a previous study, the welding process was used to build 3D parts for the first time by Baker where containers and useful shapes were produced. A scholar had successfully developed a 3D structure using a rapid prototyping process with a combination of micro tungsten inert gas (micro-TIG) welding and a layered manufacturing method [20]. The result showed that a 3D structure without mould for micro component metals with high strength and oxidation resistance can successfully be built. A previous scholar had developed a multi-layer single bed wall by combining both laser beam deposition and shaped metal deposition which two different wire-based additive layer manufacturing techniques are [21]. From their result, it is confirmed that these two processes can be used for AM applications. Jandric had focused on the manufacturing of 3D metal parts using gas tungsten arc welding (GTAW). The result showed that the 3D metal parts built have a very uniform microstructure and are free from cracks and porosity. Different with Ghariblu that had produce layered of manufacturing metal part by combining the additive and subtractive process. As a result, the part produced had improved geometric accuracy and surface quality of layered part [22].

Currently, the laser-based system and electron beam is the most common technology used to produce 3D metal parts due to the promising quality that can be produced. However, the price is high and the usage is restricted

to expensive parts only. In order to minimize costs, this project has developed a new low-cost 3d metal printing. The application of metal inert gas (MIG) welding and open source microcontroller is proposed in this study. A study showed MIG welding is a process to joining metal part by heating up to their melting point with an electric arc [23]. A significant cost reduction can be achieved, but the method used has immense benefits to the commercial 3D metal printing industry. Hence, it makes it more accessible for small and medium production to manufacture and customize parts rapidly [24].

2. DESIGN AND DEVELOPMENT

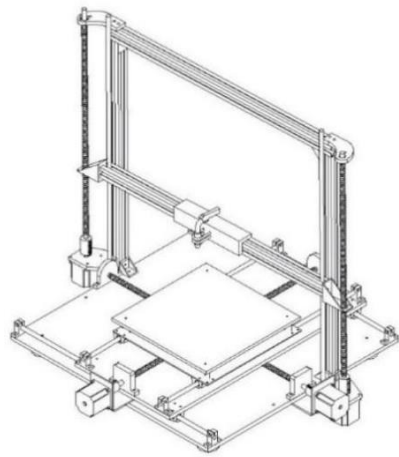

(a)

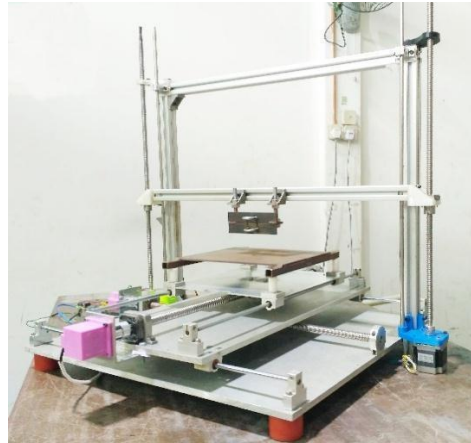

(b)

Figure 1: Comparison between the CAD design (a) and the actual newly developed low-cost 3D metal printer (b)

The components consist in developing 3D metal printer machine are; a pair of bearing holder and motor bracket, motor casing, shaft holder, ball screw, coupling, limit switch, linear bearing, stepper motor, polyurethane cylinder, polytetrafluorethylene (PTFE) plastic cylinder and various fastener. The 3D printer consists of three movement of axis which is x-axis, y-axis, and z-axis. Each axis has its respective function while moving, which is controlled by an open-source microcontroller. The x-axis functions to move the printed bed where, the movement from rotating to

linear is converted by a ball screw. The y-axis component is attached to the top of the printed bed and its function same as the x-axis but is different in terms of movement direction. However, y-axis and printed bed are separated with PTFE plastic cylinder due to high voltage current flow from MIG welding that will affect the wiring system of the microcontroller. The third axis is the z-axis, which moves the MIG nozzle in the z-direction and is powered by a two-stepper motor. Polyurethane cylinder is used to absorb all the vibration that might occur during printing process.

Table 1: Custom design printed on RepRap 3D printer machine

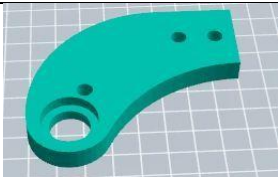
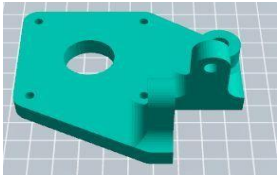
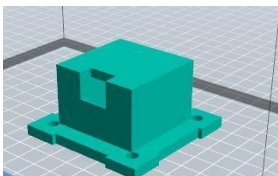
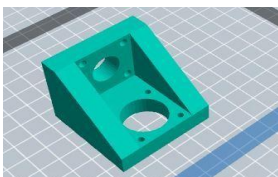
Image	Printed component	Number
	A pair of bearing holder	2
	A pair of motor bracket	2
	Motor casing	2
	Shaft holder	2

The metal inert gas welding machine (Weldone, Model: MAG 215) was used to supply the material and energy required to melt the material as shown in Figure 2. The movement of printer and the translation of command from the printer's server to host computer is controlled by firmware provided with an Arduino microcontroller. The connection of microcontroller used is as shown in Figure 3. The material costs are shown in Table 2 which includes the parts' name, quantity, and cost. The total cost of producing the 3D metal printer is about RM 3496 which is still affordable when compared to existing commercial high-end 3D metal printers available in the market.

Table 2: Material costs for the newly developed low-cost 3D metal printer

Item	Quantity	Cost (RM)
Arduino compatible MEGA 2560	1	59.00
Nema 23 stepper motor (1.8 deg)	4	400.00
Stepper driver 8825	4	54.00
Endstop switch	3	9.00
Rod bracket	8	80.00
Linear bearing	6	48.00
Ball screw set 15 mm	2	200.00
Ball screw set 8 mm	2	200.00
Coupling 5 mm x 8 mm	2	18.00
Bolt stud M10 x 2 m	1	5.00
Mild steel angle	1	13.00
Mild steel square	1	17.00
Bearing	6	18.00
U clamp	2	6.00
U joint	2	20.00

10 mm aluminum plate 628 mm x 605 mm	1	210.00
10 mm aluminum plate 628 mm x 300 mm	1	110.00
3 mm aluminum sheet 300 mm x 300 mm	1	40.00
M10 nut	9	9.00
Polyurethane cylinder	5	25.00
PTFE plastic cylinder	5	25.00
MIG welder	1	1900.00
All fasteners		30.00
Total		3496.00

In order to ensure the metal print is connected during operations, the MIG welding was set to switch on and off automatically. The shielding gas was set to flow before the printing process starts. The welding torch was placed under the fixture design perpendicular to the bed to build the surface. The distance between the bed surface and nozzle was adjusted to about 6 mm by leveling the height of the welding torch. The process used the firmware, printer interface, and slicing software. The process starts by slicing the 3D CAD model and converting it to G-code. Later, the code reads the movement in the numerically controlled programming language which then gives instruction to the 3D printer on how to make a model. During the process, the printer interface sends the G-code to the printer and the firmware interprets the G-code into actual movement. The open source firmware used was Cura which functions as a translator of the G-code into motion, thus controlling the motion of the 3D printer and giving the information when the end stop is activated or responses when problems occur. The printer starts to move to home position (0,0,0) after receiving signal from the firmware. The MIG welding starts to build from the bottom to the top area, layer by layer until one complete product is obtained. The time consumed to complete one product depends on speed used, the size of the product, and the complexity of product.

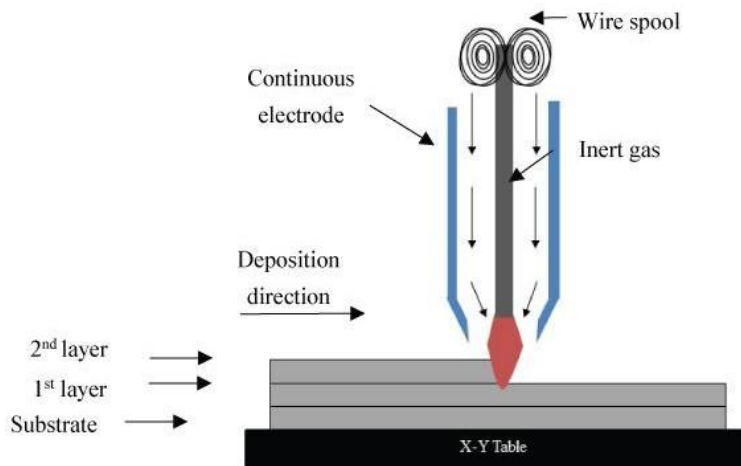

Figure 2: Illustration of MIG welding

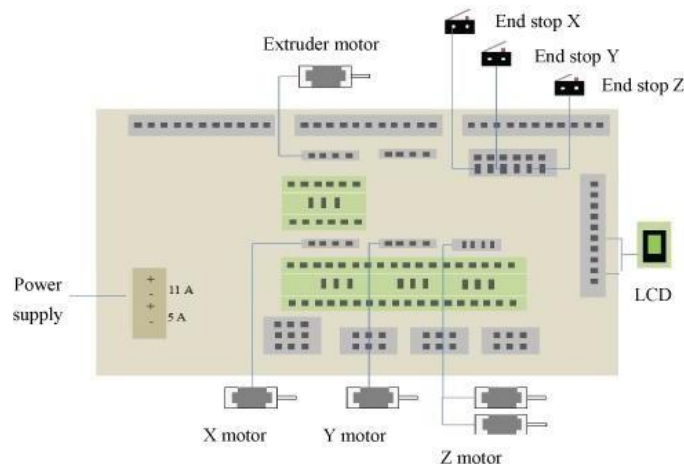

Figure 3: Connection of Arduino Mega 2560

3. EXPERIMENTAL PROCEDURE

As shown in Figure 4, the 3D metal printer machine with MIG welding used to carry out the new experimental set-up. The newly developed low-cost 3D metal printer machine has 3 axis where are x, y, and z. A welding torch is mounted to the z-axis. The deposition by welding uses MIG welding with low carbon steel alloy (ER706-S) as its material. The welding torch movement is controlled manually from their sources simultaneously with

the 3D printer machine. The z-axis moves as much as the layer height setting for every layer. The computer used to control and monitor printing process. A substrate 300 mm x 300 mm x 8 mm in size was used as the substrate base where the manufactured objects are produced onto it. In this experiment, a welding torch with wire 0.8 mm in diameter and pure argon as shielding gas were applied. The distance between welding torch and the substrate was 5 mm. The layer height was 2 mm for every layer and the density fill is 100%.

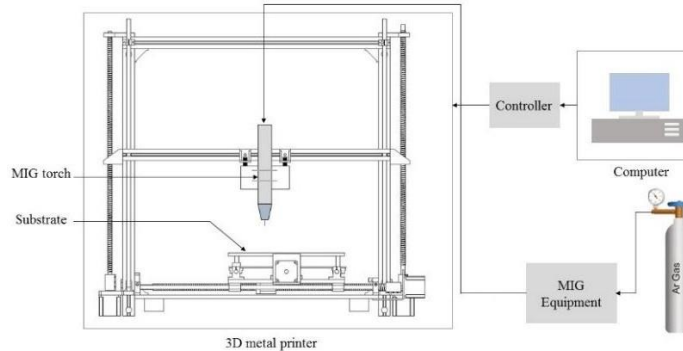

Figure 4: Arrangement of experimental apparatus setup

In order to test the performance of the newly developed low-cost 3D metal printer machine, two sets of experiment were performed. Two specimens were prepared using the 3D CAD which were a custom cylinder (40 x 25 x 30 mm) and a rectangular design (40 x 10 x 60 mm). The CATIA drawing as shown in Figure 5 is a sample of digital model that is converted to a physical object using a layer by layer printing. The aim for the first

experiment is to find the suitable voltage during 3D printing that produce relatively good bead geometry of 3D printed part. At first, the welding was deposited along the custom cylinder design. The parameter used for welding voltage varied from 18.5 V to 22.5 V. The first experiment was done with a constant speed of 50 mm/s and current of 100 A. The final dimensions were taken and compared with the actual CAD data.



Figure 5: CATIA drawing of the two specimens (a) Custom cylinder for first experiment (b) Rectangular design for the second experiment

The second experiment was designed so that capability of the newly developed machine to 3D print a rectangular shape can be analyzed. The aim of the second experiment is to find the suitable value of speed in producing good structure. The quantity of layers manufactured was observed by examining the accuracy of CAD data and scanning their surface morphology using SEM to ensure the layer perfectly coincide with each print layer. In order to evaluate the 3D print part quality, the Vickers hardness parameter was measured across the 3D printed rectangle shape. Four tests were carried out with speeds of 20, 40, 60 and 80 mm/s respectively. In each of the tests, the wire feeding speed, layer height, current, and voltage were kept constant.

4. RESULTS AND DISCUSSION

The dimensional accuracy of the component part is important, and it represents conformity between the CAD and actual 3D printed samples.

Five samples were printed for the first experiment and the average values are recorded. The final dimension was measured and the results are as shown in Figure 6(a-c) for height, inner and outer diameter. Based on the results, there is a significant difference in the print accuracy of the sample when their voltage was varied while their speed was kept constant at 50 mm/s for every sample. The result shows that none of the tests give accurate dimensions with a tolerance of ± 0.5 mm. This occurs because voltage is one of the most important factors that must be held under control. Study showed the high and low voltage gives impact on the bead geometry [27]. Excessive voltage can cause porosity, while excessive spatter produces narrow bead geometry. However, low voltage may also cause porosity and overlapping at the edges of the weld bead. Based on observation, higher voltages reduce the size of the specimen. This is due to the excessive flow of molten metal, or in the process of multi-layer deposition, the existing layer had not fully solidified but another layer is deposited onto it.

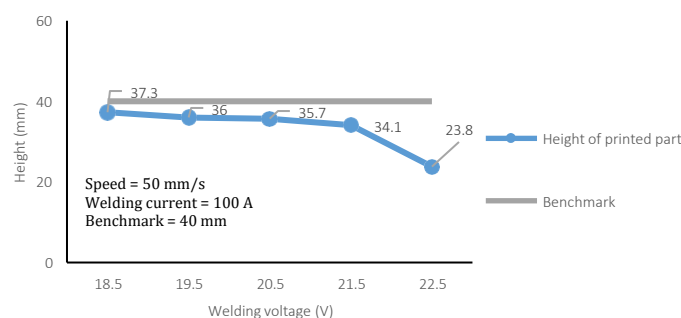

(a)

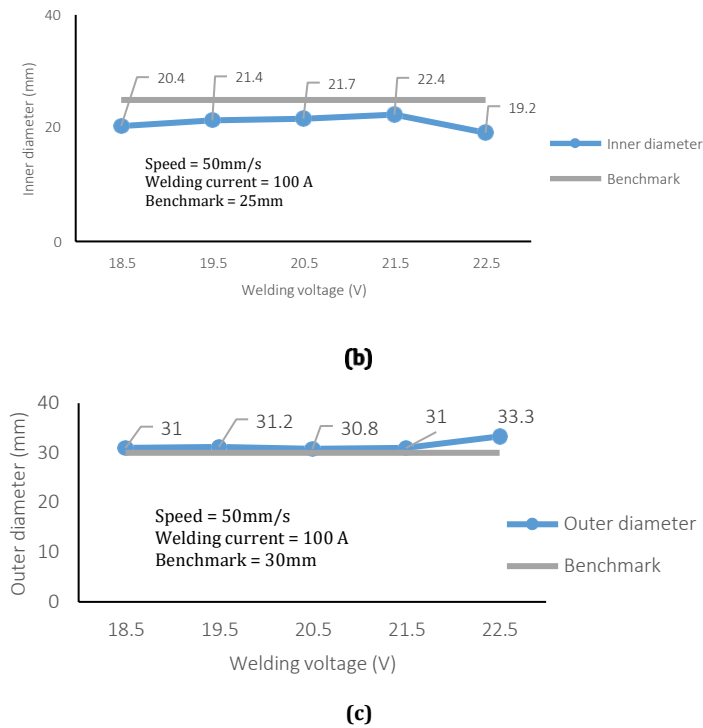

Figure 6: (a-c) Influence of voltage on the manufactured layer's (a) height, (b) inner diameter, and (c) outer diameter.

The second experiment was performed to find the suitable printing speed. This is due to the results from the previous experiment where the constant speed used is not suitable and also influences the product printed to be inaccurate according to the CAD data. According to a scholar, speed is the rate of welding that travels along the work piece and influence on consolidation of bead characteristics [28]. Slower speeds provide a larger bead size because of the longer heating time. However, if it is too slow, unusual weld build were occurred which can cause poor fusion and rough bead surface. Based on the first experiment, it was found that the voltage

setting at 20.5V produce good quality of metal part printed, but not accurate in dimension as shown in Figure 7. The low carbon steel wire (ER 706-S) with 0.8 mm in diameter was used as the material for the MIG welding. Similar parameters that were set in the first experiment were used in the second experiment except that the speed was varied while the voltage and current used were held constant. Samples at different printing speed were printed as shown in Figure 8 and the final dimensions were measured.

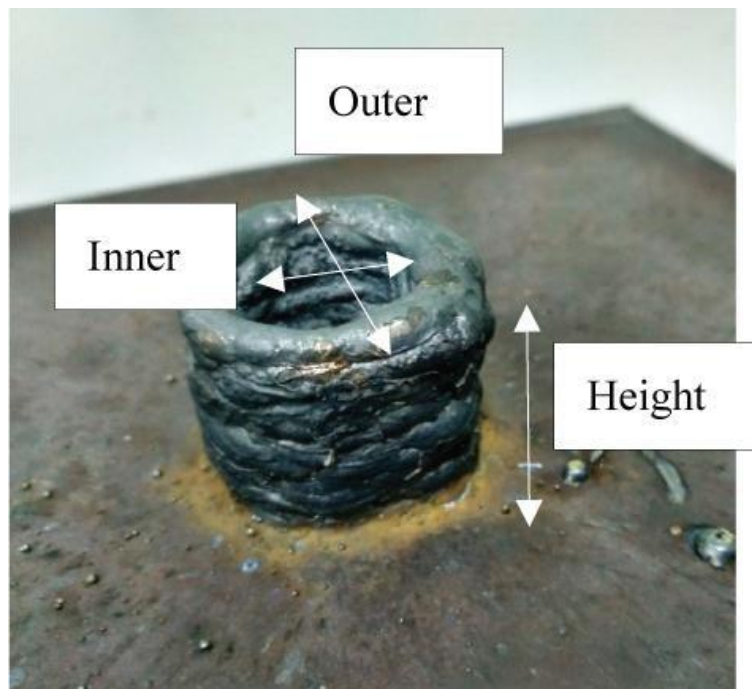

Figure 7: Printed cylindrical part from the low-cost 3D metal printer

Figure 8 shows that the higher the speed used, the higher the deposition rate were occurred, which reduces the size from the actual CAD. After the final dimensions were taken, the results show that the approximate value is 39.6 mm at 20 mm/s speed. Traditionally, welding is used for the joining process and the important criteria are the depth of penetration, rate of filler melted and stability of the process [29]. However, building the 3D layered structure requires less heat input and optimum welding speed

[30]. The value should not higher than 20 mm/s since it also related to the process of solidifying the liquid into beads. The opposite effect is that it too slow because of the high heat input due to the longer heating time which produces larger beads. Thus, the layers formed are not consistent and thus, affect the dimensional accuracy. Figure 9 shows the effect of printing speed on 3D printed height.

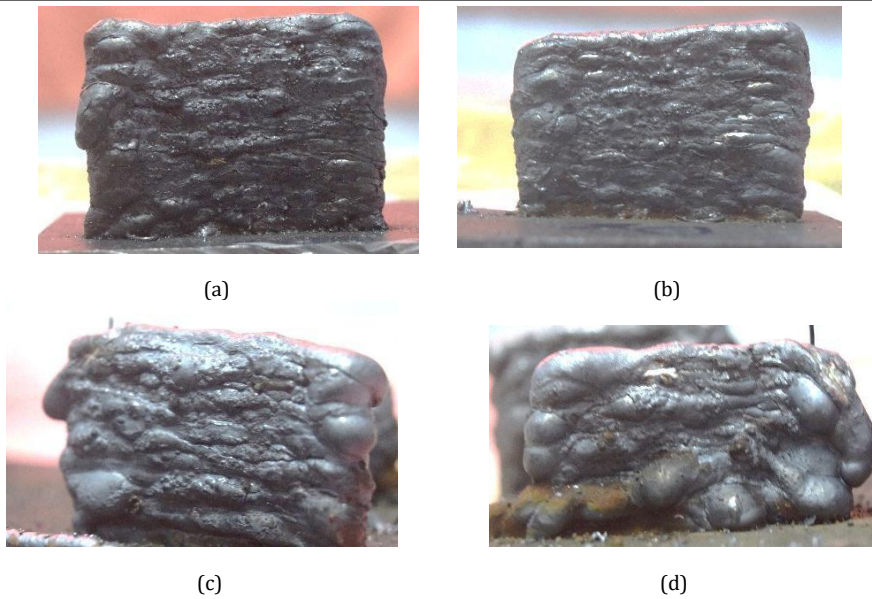

Figure 8: Output of printing process (a) speed at 20 mm/s, (b) speed at 40 mm/s, (c) speed at 60 mm/s, and (d) speed at 80 mm/s

In order to obtain more information about the weld bead geometry's microstructure, the specimen was cut cross-sectioned. The sample was grounded and polished first before etched with 2% Nital solution for approximately 10 seconds to enhance the microstructural feature for the

microscopy work. Then, the section of the specimen was analyzed using a scanning electron microscope. Figure 10 presents the microstructure of the perpendicular cross section (x-y plane) to the build direction for speeds of 20, 40, 60, and 80 mm/s.

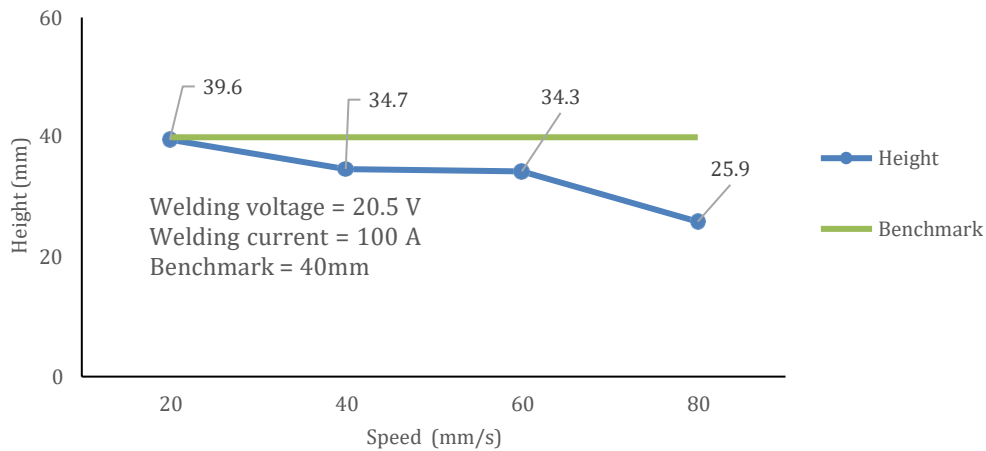

Figure 9. Effects of speed on the height of the printed part

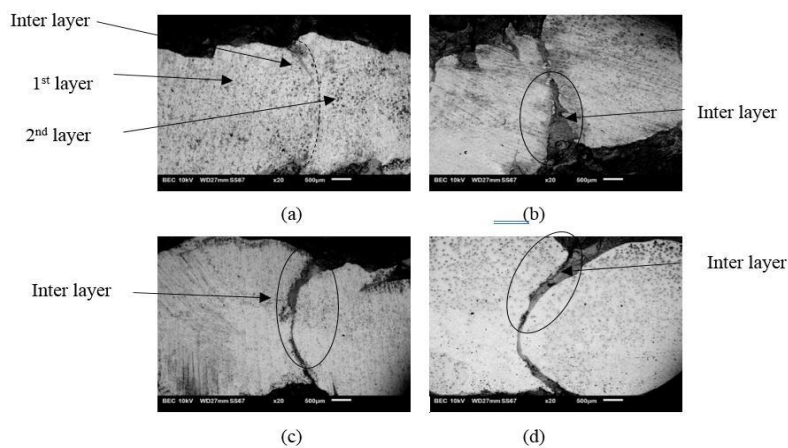

Figure 10: SEM micrographs representing various speeds to analyse the quality of multi-layer wall deposition at speeds of (a) 20 mm/s; (b) 40 mm/s; (c) 60 mm/s; and (d) 80 mm/s

The microstructure plays a role in determining the sample's properties. This research focuses on the scanning electron microscope of the cross-section layer deposition as well as how these variable selections were affected. As shown in the SEM images in Figure 10, it can be observed that the layers of depositing metal have a dense structure. However, by varying

printing speeds, the different variations of layer deposition can be observed. The result in Figure 10(a) shows that the layer perfectly coincides with each print layer when compared with Figure 10 (b) (c) and (d). The bonding between the inter-layers is poor and there is a slight curvature at the specimen edges when the speed used is increased to more than 20 mm/s. This poor bonding strength is due to the faster cooling rate

when the previous layer is not fully solidified. The micro-hardness of the manufactured layer was tested along the z direction from the bottom to the top in order to evaluate the hardness between layers as shown in Figure 11. Figure 12 shows the micro-hardness distribution along the cross-sectional area of the rectangular specimen. Its multi-layer deposition shows good bonding strength between the interlayer deposition. A minimum hardness value of 43.9 HV was found at the top manufactured layer and a maximum hardness value of 52.8 HV was found near the substrate region. The distribution of hardness value for deposited metal fluctuates along the cross-sectional area. The microhardness value at the bottom is higher than the upper region. Based on a study, the result is clearly supported by the current finding that had a similar result when depositing Inconel 625 using gas tungsten arc welding [31]. This occurs because the initial layer was deposited over the platform at room temperature, giving it a higher cooling rate, which acts as a heat sink compared to the subsequent layer. According to a researcher, the hardness at the bottom region can be minimized by preheating the substrate, or

through a post-deposition heat treatment process [32].

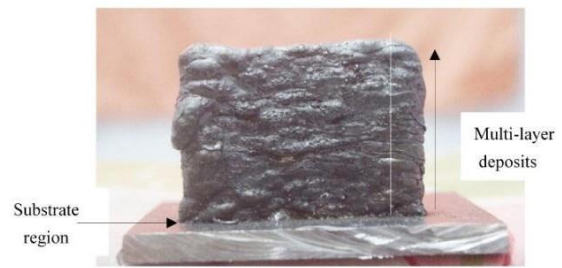

Figure 11: Cross-section of x-z plane

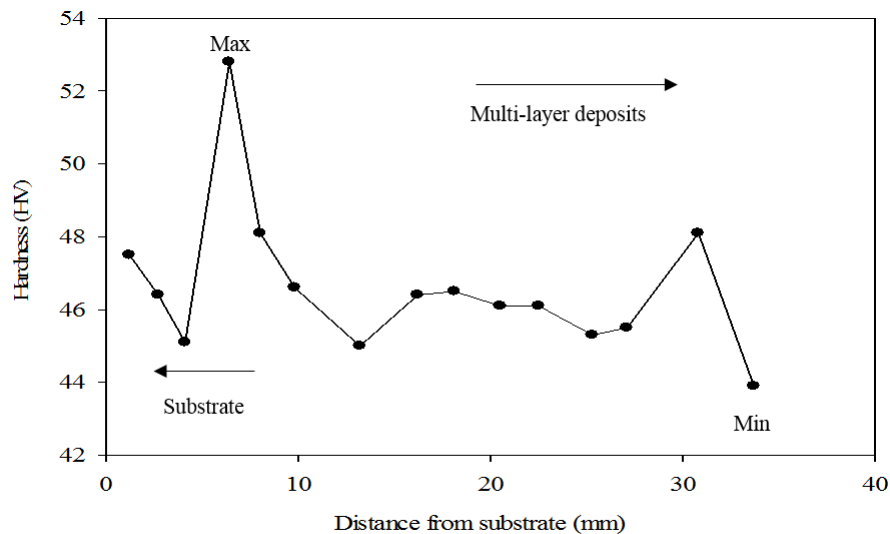

Figure 12. Micro-hardness distribution along multi-layer deposited sample

5. CONCLUSION

In the present study, a new low-cost 3D metal printer has been designed and developed. The mechanism used is derived and improved design from the existing Prusa i3 open source system and capable of printing metal parts. The newly developed low-cost 3D metal printer is useful for small companies which require low production quantities and customized production but are not able to afford the existing commercial 3D metal printers. However, secondary processing is required in order to get better surface finish. Nevertheless, the study demonstrated that simple design specimens were successfully fabricated using the MIG welding and 3D printing process. The microstructure shows that the layer perfectly coincides with each printer layer and the top region of manufactured layer has the lowest hardness compared to the initial layer. However, further research needs to be done in the future to improve the product's quality and to study the mechanical behavior of the parts produced by this technique.

ACKNOWLEDGEMENT

The authors would like to thank Universiti Teknikal Malaysia Melaka (UTeM), and Ministry of Science, Technology and Innovation (MOSTI) for research grant 03-01-14-SF0145.

REFERENCES

- [1] Udroui, R., Nedelcu, A. 2011. Optimization of Additive Manufacturing Process Focused on 3D Printing, INTECH Open Access Publisher.
- [2] Kruth, J.P., Levy, G., Klocke, F., Childs, T.H.C. 2007. Consolidation phenomena in laser and powder-bed based layered manufacturing, CIRP Annals - Manufacturing Technology, 56, (2), 730-759.
- [3] Galantucci, L.M., Lavecchia, F., and G. Percoco, G. 2008. Study the compression properties of topologically optimized FDM made structured parts, CIRP Annals - Manufacturing Technology, 57, (1), 243-246.

- [4] Galantucci, L.M., Bodi, I., Kacani, J., Lavecchia, F. 2015. Analysis of dimensional performance for a 3D open-source printer based on fused deposition modelling technique, Procedia CIRP, 28, 82-87.
- [5] Majid, S.N.A., Alkahari, M.R., Ramli, F.R., Maidin, S., Fai, T.C., Sudin, M.N. 2017. Influence of Integrated Pressing during Fused Filament Fabrication on Tensile Strength and Porosity, Journal of Mechanical Engineering, 2, 185-195.
- [6] Nazan, M.A., Ramli, F.R., Alkahari, M.R., Sudin, M.N., Abdullah, M.A. 2017. Process Parameter Optimization of 3D Printer using Response Surface Method, ARPN Journal of Engineering and Applied Sciences, 12 (7), 2291-2296.
- [7] Mazlan, S.N.H., Alkahari, M.R., Ramli, F.R., Sudin, M.N., Maidin, N.A., Oii, K.S. 2018. Manufacturability of Mechanical Structure Fabricated using Entry Level 3D Printer, Journal of Mechanical Engineering, 5 (3), 98-122.
- [8] Nazan, M.N., Ramli, F.R., Alkahari, M.R., Sudin, M.N., Abdullah, M.A. 2016. Optimization of warping deformation in open source 3D printer using response surface method, in Proceedings of Mechanical Engineering Research Day, 71-72.
- [9] Pearce, J.M. 2013. Open-source Lab: How to build your own hardware and reduce research costs, Newnes.
- [10] Ramli, F.R., Jailani, M.I., Unjar, H., Alkahari, M.R., Abdullah, M.A. 2015. Integrated recycle system concept for low cost 3D-printer sustainability, Proceedings of Mechanical Engineering Research, 77-78.
- [11] Lanzaotti, A., Matorelli, M., Staino, G. 2015. Understanding Process Parameter Effect of RepRap Open Source Three-Dimensional Printers Through a Design of Experiment Approach, Journal of Manufacturing Science and Engineering, 137, (1), 11-017.
- [12] Anzalone, G.C., Zhang, C., Wijnen, B., Sanders, P.G., Pearce, J.M. 2013. A low-cost open-source metal 3-D printer, IEEE Access, (1), 803-810.

- [13] Jandric, Z., Labudovic, M., Kovacevic, R. 2004. Effect of heat sink on microstructure of three-dimensional part built by welding-based deposition, *International Journal of Machine Tools and Manufacture*, 44 (7), 785-796.
- [14] Alkahari, M.R., Furumoto, T., Ueda, T., Hosokawa, A. 2014. Melt Pool and Single Track Formation in Selective Laser Sintering/Selective Laser Melting, *Advanced Materials Research*, 933, 196-201.
- [15] Mazumder, J., Choi, J., Nagarathnam, K., Koch, J., Hetzned, D. 1997. The direct metal deposition of H13 tool steel for 3-D componenets, *Journal of the Minerals, Metals, and Materials Society*, 49, (5), 55-60.
- [16] Baufeld, B., Van der Biest, O., Gault, R. 2010. Additive manufacturing of Ti-6Al-4V component by shaped metal deposition: microstructure and mechanical properties, *Material and Design*, 32, 106-111.
- [17] Baufeld, B., Van der Biest, O., Gault, R., Ridgway, K. 2011. Manufacturing Ti-6Al-4V component by shaped metal deposition: microstructure and mechanical properties, *IOP conference series: Material science and engineering*, 26, (1), 012001.
- [18] Brandl, E., Leyens, C., Palm, F., Schoberth, A., Onteniente, P. 2004. Mechanical properties of additive manufacturing Ti-6Al-4V using wire and powder-based process, *IOP Conference Series: Material Science and Engineering*, 26, (1).
- [19] Marina, F., Mehnen, F.J., Williams, J.S.W., Colegrove, P., Wang, F. 2012. Investigation the benefits of plasma deposition for the additive layer manufacture of Ti-6Al-4V, *Journal of Material Processing Technology*, 212, (6), 1377-1386.
- [20] Horii, T., Kirihara, T.S., Miyamoto, Y. 2009. Freeform fabrication of superalloy objects by 3D micro welding, *Material and Design*, 30, (4), 1093-1097.
- [21] Brandl, E., Baufeld, B., Leyens, C., Gault, R. 2010. Additive manufacturing Ti-6Al-4V using welding wire: comparison of laser and arc beam deposition and evaluation with respect to aerospace material specifications, *Physics Procedia*, 5, 595-606.
- [22] Ghariblu, H., Rahmati, S. 2014. New process and machine for layered manufacturing of metal parts, *Journal of Manufacturing Science and Engineering*, 136, (4), 041004
- [23] Zainal, A.S., Arif, M., Hanim, A. 2014. The effect of welding parameters on butt joints using robotic gas metal arc welding, *Journal of Mechanical Engineering and Science*, 6, 988-994.
- [24] Pinar, A., Wijnen, B., Anzalone, G.C., Havens, T.C., Sanders, P.G., Pearce, J.M. 2015. Low cost open-source voltage and current monitor for gas metal arc weld 3D printing, *Journal of Sensors*.
- [25] 2016. Prusa i3 3D printer - Prusa Printers. Prusa Printers. <http://www.prusaprinters.org/prusa-i3/>
- [26] Lan, J. 2013. Design and fabrication of a modular multi-material 3D printer. Doctoral dissertation, Ph.D. thesis, Massachusetts Institute of Technology.
- [27] Patel, U.A. 2015. Optimization of Process Parameter in MIG Welding Process on Dissimilar Material by using Artificial Neural Network, Ph.D. thesis, Ganpat University.
- [28] Alkahari, M.R., Furumoto, T., Ueda, T., Hosokawa, A. 2014. Consolidation characteristics of ferrous-based metal powder in additive manufacturing, *Journal of Advanced Mechanical Design, Systems, and Manufacturing*, 8, (1).
- [29] Karunakaran, K.P., Suryakumar, S., Pushpa, V., Akula, S. 2010. Low cost integration of additive and subtractive process for hybrid layered manufacturing, *Robotics and Computer-Integrated Manufacturing*, 26, (5), 490-499.
- [30] Kovacevic, R., Beardsley, H. 1998. Process Control of 3D welding as a Droplet-Based Rapid Prototyping Technique, in *Proceedings of the SFF symposium*, University of Texas, 57-64.
- [31] Wang, J.F., Sun, Q.J., Wang, H., Liu, J.P., Feng, J.C. 2016. Effect of location on microstructure and mechanical properties of additive layer manufactured Inconel 625 using gas tungsten arc welding, *Materials Science and Engineering*, 676, 395-405.
- [32] Jhavar, S., Jain, N.K. 2014. Development of Micro-Plasma Wire Deposition Process for Layered Manufacturing, *DAAM International Scientific Book*, 20, 239-256.